



# VIC429ST VIDEO IMAGING CHAIR OPERATING MANUAL

**SAVE THIS MANUAL FOR FUTURE USE.**

# CONTENTS

INTRODUCTION – A WORD FROM GF HEALTH PRODUCTS, INC.....	4
INDICATIONS FOR USE .....	4
SERVICE INFORMATION.....	4
ADVISORY .....	4
1 LIST OF WARNINGS AND CAUTIONS.....	5
SIGNIFICANCE OF SAFETY STATEMENTS.....	5
DANGER / WARNING / CAUTION / NOTICE SUMMARY.....	5
WARNING: TO REDUCE THE RISK OF PERSONAL INJURY .....	5
WARNING – CAUTIONS AND PROPER OPERATION .....	6
2 UNCRATING INSTRUCTIONS .....	7
IMPORTANT – REPORT ANY SHIPPING DAMAGE IMMEDIATELY .....	7
NOTICE – POSSIBLE EQUIPMENT DAMAGE .....	7
WARNING – PERSONAL INJURY HAZARD.....	7
ENVIRONMENTAL CONDITIONS .....	7
OPERATING.....	7
STORAGE AND TRANSPORT .....	7
UNPACKING INSTRUCTIONS .....	7
3 OPERATING INSTRUCTIONS.....	8
3.1 VIC429ST FEATURES .....	8
3.1.1 VIC429ST STANDARD FEATURES.....	8
3.1.2 VIC429ST FEATURES, WARNINGS, AND PROPER OPERATION INSTRUCTIONS...	9
3.1.3 VIC429ST FEATURES, ILLUSTRATED .....	10
3.2 VIC429ST SPECIFICATIONS .....	11
3.3 BRAKING AND STEERING OPERATION.....	12
3.3.1 APPLYING THE BRAKES .....	12
3.3.2 RELEASING THE BRAKES .....	12
3.3.3 APPLYING THE STEERING LOCK .....	12
3.3.4 RELEASING THE STEERING LOCK.....	12
3.4 TOP AND BACK ADJUSTMENT .....	13
3.4.1 RAISING THE TOP .....	13
3.4.2 LOWERING THE TOP.....	13
3.4.3 RECLINING THE CHAIR BACK .....	14
3.4.4 RETURNING THE CHAIR BACK TO UPRIGHT POSITION .....	14
3.4.5 TRENDELENBURG POSITION .....	14
3.5 INDEPENDENT LEG SECTION .....	15
3.5.1 INDEPENDENT LEG OPERATION.....	15
3.5.2 RETURNING TO CHAIR MODE.....	15

<b>3.6</b>	<b>ADJUSTABLE FOOTREST</b> .....	<b>16</b>
<b>3.6.1</b>	<b>REPOSITIONING THE FOOTREST</b> .....	<b>16</b>
	TO PLACE FOOTREST IN LOWER POSITION: .....	16
	TO PLACE FOOTREST IN UPPER POSITION: .....	16
	TO RETURN THE FOOTREST TO RETRACTED POSITION: .....	16
<b>3.7</b>	<b>HINGING RAILS</b> .....	<b>17</b>
<b>3.7.1</b>	<b>REPOSITIONING THE RAIL</b> .....	<b>17</b>
	TO LOWER THE RAIL: .....	17
	TO RAISE THE RAIL:.....	17
<b>3.8</b>	<b>VIC ROTATING INSTRUCTIONS (TRANSPORT AND NONTRANSPORT MODE)</b> .....	<b>18</b>
<b>3.8.1</b>	<b>MODE DEFINITIONS</b> .....	<b>18</b>
	TRANSPORT MODE.....	18
	NONTRANSPORT MODE.....	18
<b>3.8.2</b>	<b>NONTRANSPORT MODE (ANTERIOR / POSTERIOR POSITION)</b> .....	<b>19</b>
	TO ENTER NONTRANSPORT MODE .....	19
<b>3.8.3</b>	<b>TRANSPORT MODE (LATERAL POSITION)</b> .....	<b>19</b>
	TO ENTER TRANSPORT MODE.....	19
<b>3.9</b>	<b>PATIENT TRANSFER INSTRUCTIONS</b> .....	<b>20</b>
	DEFINITION OF TERMS USED IN THE FOLLOWING INSTRUCTIONS (SEE FIG. 3.10-1 BELOW).....	20
	TRANSFER SIDE TERMS.....	20
	TRANSFER OF PATIENT FROM VIC TO A SECONDARY DEVICE.....	20
<b>3.10</b>	<b>PERFORMING PATIENT TRANSFER</b> .....	<b>21</b>
	PATIENT TRANSFER.....	21
	PATIENT TRANSFER FROM A SECONDARY DEVICE TO VIC .....	21
<b>4</b>	<b>PREVENTIVE MAINTENANCE FOR THE USER</b> .....	<b>22</b>
<b>5</b>	<b>OPTIONAL ACCESSORIES</b> .....	<b>23</b>
<b>6</b>	<b>GF HEALTH PRODUCTS, INC. LIMITED WARRANTY FOR HAUSTED BRAND STRETCHERS AND CHAIRS</b> .....	<b>24</b>
<b>7</b>	<b>DISPOSAL AND KEY TO SYMBOLS</b> .....	<b>26</b>
	DISPOSAL.....	26
	KEY TO SYMBOLS .....	26
<b>8</b>	<b>INDEX</b> .....	<b>27</b>

## **COPYING PROHIBITED**

This manual is protected by Federal Copyright Law, which provides for damages of up to USD \$20,000, as well as criminal fines and imprisonment, for unauthorized copying.

## INTRODUCTION — A WORD FROM GF HEALTH PRODUCTS, INC.

This manual contains important information on proper use and maintenance of the Hausted VIC429ST Video Imaging Chair. All personnel involved in the use and maintenance of this equipment must carefully review and comply with the warnings, cautions and instructions contained in this manual. These instructions are important to protect the health and safety of personnel operating the model VIC429ST Video Imaging Chair, and should be retained in a conveniently accessible area for quick reference.

Complete instructions for uncrating and putting your new equipment in service, as well as equipment drawings, have been furnished. If missing, contact GF Health Products, Inc. for replacement copies, giving the serial number and model number of the unit.

GF Health Products, Inc. carries a complete line of accessories for use with these chairs; your representative will gladly review these with you.

### Indications for Use

The Hausted VIC429ST Video Imaging Chair, with a radiolucent back for X-ray imaging, is intended for use in patient treatment, transport or recovery.

### Service Information

A thorough preventive maintenance program is essential to safe and proper unit operation. This manual contains maintenance schedules and procedures which should be followed for satisfactory equipment performance.

We encourage you to contact GF Health Products, Inc. with maintenance concerns.

### Advisory

A listing of the safety precautions to be observed when operating and servicing this equipment can be found in Section 1 of this manual. Do not operate or service the equipment until you have become familiar with this information. Any alteration of this equipment not authorized or performed by GF Health Products, Inc., could affect its operation, will void the warranty, could violate national, state, and local regulations, and could jeopardize your insurance coverage.

*Info: Column 1 below applies only if product was purchased outside the U.S.*

	
<b>EU Authorized Representative:</b>	
AR Experts BV	
Boeingavenue 209	
1119 PD Schiphol-Rijk	
The Netherlands	
<a href="http://www.ar-experts.eu">www.ar-experts.eu</a>	

	<b>Manufactured by:</b>
	GF Health Products, Inc.
	One Graham-Field Way
	Atlanta GA 30340-3140
	1.770.368.4700 Main
	1.770.368.2386 Fax
	<a href="http://www.grahamfield.com">www.grahamfield.com</a>
	<a href="http://www.Hausted.com">www.Hausted.com</a>

*Info: The base language of this document is ENGLISH. Any translations must be made from the base language document.*

# 1 LIST OF WARNINGS AND CAUTIONS

**⚠ IMPORTANT: Before using the Hausted VIC429ST Video Imaging Chair, please read and adhere to the following safety precautions and warnings. Failure to do so could result in serious personal injury or damage to the VIC429ST Video Imaging Chair.**

Always consult your healthcare professional to determine safe methods most suitable for your individual abilities. Protect yourself, your attendant, and the Hausted VIC429ST Video Imaging Chair by having it serviced regularly. If you experience any malfunction, contact your Graham-Field authorized distributor immediately, as a hazardous condition could result, causing personal injury or damage to the Hausted VIC429ST Video Imaging Chair.

Periodic inspection, adjustment and replacement of worn parts are necessary to provide years of excellent service. Maintenance **MUST** be performed by qualified personnel **ONLY**.

**SAVE THESE INSTRUCTIONS.**

## SIGNIFICANCE OF SAFETY STATEMENTS

Please note the following special statements, used throughout this manual, and their significance:

**⚠ DANGER:** Indicates a potential hazard situation or unsafe practice that, if not avoided, will result in death or serious personal injury.

**⚠ WARNING:** Indicates a potential hazard situation or unsafe practice that, if not avoided, could result in death or serious personal injury.

**⚠ CAUTION:** Indicates a potential hazard situation or unsafe practice that, if not avoided, could result in minor or moderate personal injury.

**▲ NOTICE:** Indicates a potential hazard situation or unsafe practice that, if not avoided, could result in product or property damage.

*Info: Provides application recommendations or other useful information to ensure that you get the most from your product.*

## DANGER / WARNING / CAUTION / NOTICE Summary

The following is a listing of the safety precautions which must be observed when operating and servicing this equipment. These precautions are repeated (in whole or in part), where applicable, throughout the manual.

### WARNING: To Reduce the Risk of Personal Injury

**⚠ WARNING: LACERATION HAZARD – When cutting bands always use a tool specifically designed for that purpose. This will help to avoid personal injuries frequently incurred when bands are cut and tension released.**

## **WARNING — CAUTIONS AND PROPER OPERATION**

- ⚠ WARNING:** The VIC429ST Video Imaging Chair has a maximum patient weight capacity of 147 kg (324 lb), **EVENLY DISTRIBUTED.**
- ⚠ WARNING:** The VIC429ST Video Imaging Chair has a maximum weight, including equipment weight and maximum patient weight, of 494 lb (224 kg), **EVENLY DISTRIBUTED.**
- ⚠ WARNING:** The chair is not intended to replace a stretcher or gurney.
- ⚠ WARNING:** The chair has warning labels on both the head and foot end stating: **Do not sit on end — as tipping may occur.**
- ⚠ WARNING:** **Do not stand on footrest — tipping may occur.**
- ⚠ WARNING:** **When not in use, do not leave the chair in a recline position.**
- ⚠ WARNING:** **When patient is seated in the chair, ensure the side rails are up and the patient is secured with patient safety straps.**
- ⚠ WARNING:** **Patient entry, egress and transfer from the chair should always be from the center side rail location with the side rail in the down position and the brakes locked.**
- ⚠ WARNING:** **At no time should the patient be permitted to enter or exit from the ends of the chair when in partial or total recline position.**
- ⚠ WARNING:** **Ensure the brakes are locked when the patient is not being transported.**
- ⚠ WARNING:** **Steam cleaning and pressure washing of chair is not recommended and can void warranty.**

## 2 UNCRATING INSTRUCTIONS

### IMPORTANT – REPORT ANY SHIPPING DAMAGE IMMEDIATELY

⚠ **WARNING:** Inform shipper of any damages – leave carton intact. Leave equipment in the receiving area until inspection is complete.

### NOTICE – POSSIBLE EQUIPMENT DAMAGE

▲ **NOTICE:** The crate contains fragile, expensive medical equipment. Uncrate and handle carefully. If after uncrating the equipment you find any damage (no matter how slight), report the damage to GF Health Products, Inc.

### WARNING – PERSONAL INJURY HAZARD

⚠ **WARNING:** When cutting bands, always use tool specifically designed for that purpose. This will help avoid personal injuries possibly incurred when bands are cut and tension is released.

### ENVIRONMENTAL CONDITIONS

Operating	
Temperature	5°C to 40°C
Relative Humidity	20% to 90% @ 30°C
Atmospheric Pressure	700 to 1060 hPa

Storage and Transport	
Temperature	-10°C to 50°C
Relative Humidity	20% to 90% @ 30°C
Atmospheric Pressure	700 to 1060 hPa

### UNPACKING INSTRUCTIONS

**IMPORTANT:** Follow each step in the order shown in these instructions.

Your Hausted equipment has been carefully packed at our manufacturing plant to ensure safe shipment to your medical facility. There are several procedures you must follow to put your new equipment in service. These procedures only take a few minutes to complete and all are required to ensure proper operation of the equipment.

1. Cut the two bands around the shipping carton.
2. Remove the top cap of the carton and remove the two box side panels.
3. Remove the equipment from the carton.
4. Check to see if all features of the equipment work properly. If all the features work, advance to step 5. If any of the features do not work properly, call GF Health Products, Inc. at 1.770.368.4700.
5. Clean the equipment using mild detergent to remove any dirt accumulated during shipment, and place the equipment into service.

## 3 OPERATING INSTRUCTIONS

### 3.1 VIC429ST FEATURES

#### 3.1.1 VIC429ST Standard Features

- Pneumatic-assist back angle
- Radiolucent back section provides a clear, unobstructed site for imaging used during transport, easy to remove for radiological procedures
- Easy-to-operate rotating seat section
- Dual side hydraulic foot pedal controls height adjustment
- Four-wheel brake and steer system
- Independent leg section
- Fold-down height-adjustable footrest
- Accessory wells (two on each side)
- Built-In chart holder
- Removable push handles
- Four hook and loop safety straps for patient head, chest, waist and legs

### 3.1.2 VIC429ST Features, Warnings, and Proper Operation Instructions

#### WARNINGS – CAUTIONS AND PROPER OPERATION (See Diagram on following page)

- ⚠ **A. WARNING:** The VIC429ST Video Imaging Chair has a maximum patient weight capacity of 324 lb (147 kg), **EVENLY DISTRIBUTED.**
- ⚠ **B. WARNING:** The VIC is not intended to replace a stretcher or gurney.
- ⚠ **C. WARNING:** The chair has warning labels on both the head and foot end stating: **Do not sit on end - as tipping may occur.**
- ⚠ **D. WARNING:** Do not stand on footrest — tipping may occur.
- ⚠ **E. WARNING:** When the VIC is not in use, do not leave it in a recline position.
- ⚠ **F. WARNING:** When patient is seated in the chair, ensure the side rails are up and the patient is secured with patient safety straps.
- ⚠ **G. WARNING:** Patient entry, egress and transfer from the chair should always be from the center side rail location with the side rail in the down position and the brakes locked.
- ⚠ **H. WARNING:** At no time should the patient be permitted to enter or exit from the ends of the VIC when in partial or total recline position.
- ⚠ **I. WARNING:** When transporting patient, the patient should be placed in a fully upright position with chair in low height. The patient should never be transported when the VIC is in a recline position.
- ⚠ **J. WARNING:** The brakes should always be applied when patient is not being transported.
- ⚠ **K. WARNING:** The VIC has a warning label on the top of the base cover that states: **When chair is in nontransport mode: patient must remain fully upright; patient must never be reclined; patient must never be left unattended.**

### 3.1.3 VIC429ST Features, Illustrated

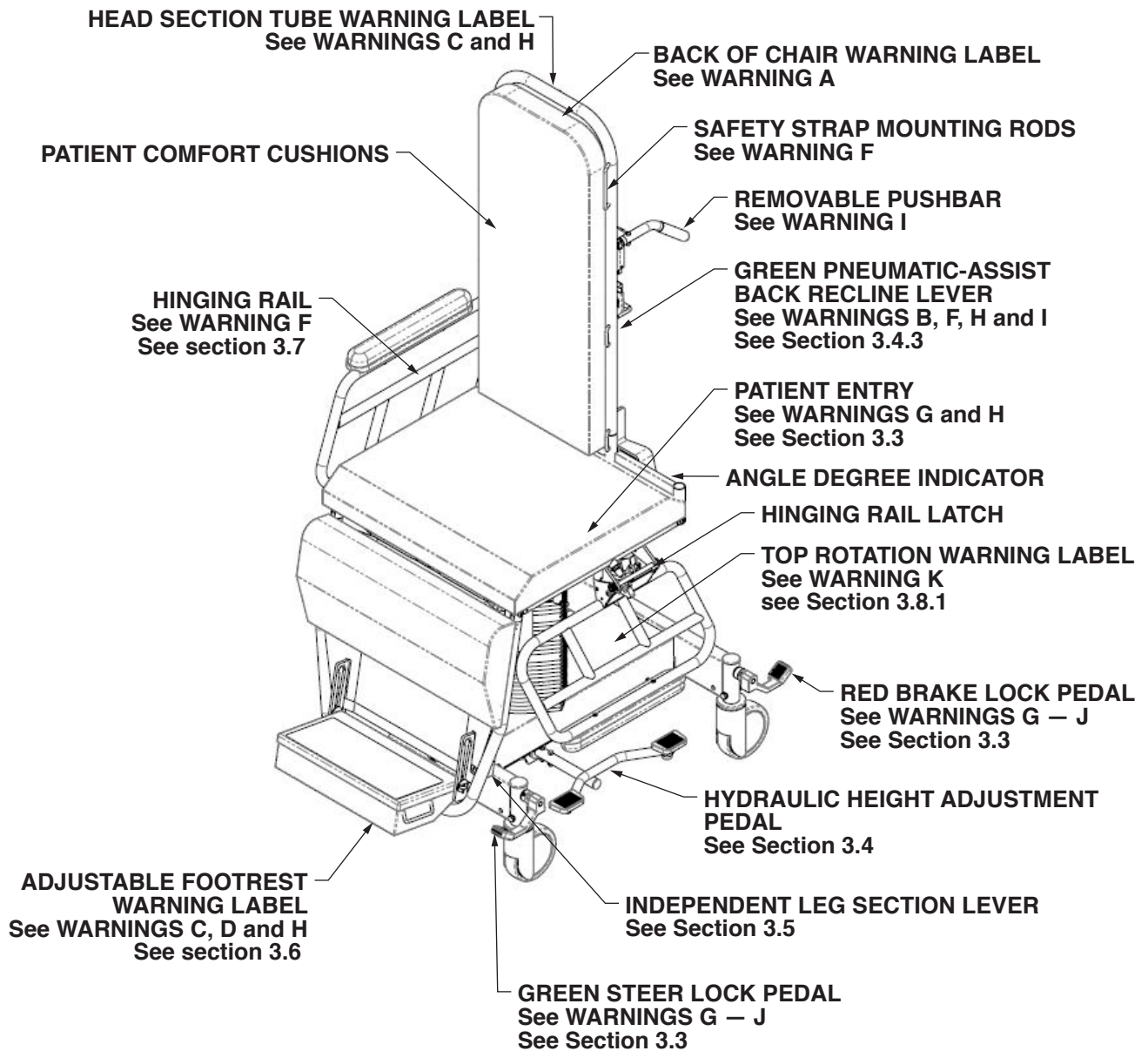

### 3.2 VIC429ST SPECIFICATIONS

*Info: All dimensions are specified in inches and centimeters. Unless otherwise noted, all dimensions are ± .375 in. (1 cm).*

VIC429ST Specification	Chair Position		Stretcher Position	
	inch	cm	inch	cm
Patient Surface Size (WxL)	22 x 50	55.9 x 127.0	22 x 70.5	55.9 x 179.1
Unit Height	58.5 to 66.5	148.6 to 168.9	24 to 31.5	61.0 to 80.0
Overall Width	27	68.58	27	68.58
Back Section Width	14	35.6	14	35.6
Overall Length	-	-	76.5	194.31
Caster ( Easy Roll) Diameter	5	12.7	5	12.7
Pad, Multi-Density Sectional, Thickness	3	7.6	3	7.6
Side Rail Length	22	55.88	22	55.88
Side Rail Height	12	30.48	12	30.48
Sectional Pad (thickness)	3	7.62	3	7.62

VIC429ST Specification	lb	kg
Product Weight	170	77
Shipping Weight	295	133.81
Maximum Weight Capacity, Evenly Distributed	325	147.42

VIC429ST Specification	degree
Trendelenburg Position Standard	-10
Trendelenburg Position Reverse	0
Seat Tilt	0
Back Range (infinite adjustment between points)	-10 (Trendelenburg position) to 90 (chair position)

### 3.3 BRAKING AND STEERING OPERATION

⚠ **WARNING:** Patient entry, egress and transfer from the VIC should always be from the center side rail location with the side rail in the down position and brakes locked.

⚠ **WARNING:** The brakes should always be applied when patient is not being transported.

#### 3.3.1 Applying the Brakes

To activate the four-wheel central-braking system, depress the red pedal on the patient's left at VIC foot end, shown circled in red in Fig. 3.3-1. To fully engage the brakes, the pedal should be depressed to approximately 45°. All four casters will then be locked from swiveling and rotating.

#### 3.3.2 Releasing the Brakes

To release the four-wheel central-braking system, depress the green pedal on the patient's left at the VIC head end, shown circled in red in Fig. 3.3-2, until the pedal is in a horizontal position (Fig. 3.3-3). All four wheels will then rotate and swivel freely.

#### 3.3.3 Applying the Steering Lock

From the VIC head end, depress the green pedal downward into locked position (Fig. 3.3-2), then push the VIC forward; both foot-end casters will lock into non-swivel mode to allow straight steering by the attendant when pushing from the head end.

#### 3.3.4 Releasing the Steering Lock

To release the steering lock, depress the red pedal at either VIC right side corner until the pedal is in a horizontal position (Fig. 3.3-2). All four wheels will then rotate and swivel freely.



Figure 3.3-1



Figure 3.3-2



Figure 3.3-3

## 3.4 TOP AND BACK ADJUSTMENT

### WARNING: PERSONAL INJURY HAZARD:

- ⚠ **WARNING:** When the VIC is not in use, do not leave it in a recline position.
- ⚠ **WARNING:** At no time should the patient be permitted to enter or exit from the ends of the VIC when in partial or total recline position.
- ⚠ **WARNING:** When transporting patient, the patient should be placed in a fully upright position with chair in low height.
- ⚠ **WARNING:** The patient should never be transported when the VIC is in recline position.
- ⚠ **WARNING:** The VIC has a warning label on the top of the base cover that states: When chair is in nontransport mode: patient must remain fully upright; patient must never be reclined; patient must never be left unattended.

### 3.4.1 Raising the Top

Press the pump pedal (pedal nearest the head end) to the floor (Fig. 3.4-1), then release the pressure on the pedal. Repeat this process until the top is raised to the desired height. Use smooth strokes while pumping pedal to ensure patient comfort.



Figure 3.4-1

### 3.4.2 Lowering the Top

Press down on the release pedal (pedal nearest the foot end) until the top is lowered to the desired height.



Figure 3.4-2

### 3.4.3 Reclining the Chair Back

Squeeze the green recline lever (Fig. 3.4-3) and push back on the back section until the desired position is obtained. Position can vary from upright to -10° Trendelenburg position.

*Info: There is a degree indicator, circled in red in Fig. 3.4-5, located on the lower back section on the side of the chair.*

### 3.4.4 Returning the Chair Back to Upright Position

To return the back to upright position, squeeze the recline lever and lift up on the back section (Fig. 3.4-4).

### 3.4.5 Trendelenburg Position

The VIC back has a Trendelenburg range of 0° (horizontal position, shown in Fig. 3.4-5) to -10° (Trendelenburg position).

To activate Trendelenburg position from any other position, depress the green recline lever shown in Fig 3.4-3. Allow the back to lower into the desired degree of Trendelenburg position.

To return the back to upright position, squeeze the recline lever, lift up on the back section (Fig. 3.4-4), and allow the back section to rise into the desired angle up to 90° (upright position).



Figure 3.4-3\*\*\*



Figure 3.4-4



Figure 3.4-5

\*\*\*Chair shown in Sure-Check Fusion III Spruce (XXX-043)

## 3.5 INDEPENDENT LEG SECTION

### WARNING: PERSONAL INJURY HAZARD:

⚠ **WARNING:** The VIC has a warning label on the top of the base cover that states: **When chair is in nontransport mode: Patient must remain fully upright; patient must never be reclined; patient must never be left unattended.**

The VIC back and leg positions are dependent on each other in the standard operating mode: as the back position is adjusted, the leg position follows.

The leg position can be independently positioned, however.

### 3.5.1 Independent Leg Operation

Hold and support the leg section by the bottom of the frame tube and pull out on the end of the red lever (Fig. 3.5-1). Rotate the lever clockwise while positioning the leg section (Fig. 3.5-2).

Once desired position of the leg section is reached, release the lever and the leg section will be locked in place (Fig. 3.5-3). When the leg section is independent, it can be repositioned at any time by turning the lever clockwise (Fig. 3.5-3).

▲ **NOTICE: ALWAYS** support the leg section when turning the red lever.

### 3.5.2 Returning to Chair Mode

Hold and support the leg section by the bottom of the frame tube and push in on the end of the red lever (Fig. 3.5-1). Rotate the lever counterclockwise while positioning the leg section (Fig. 3.5-4). The lever will slide inward to an inactive position; once the lever is inactive, adjust the leg section until it is aligned with the back section (Fig. 3.5-5).

**Info:** You will hear the leg section click into place as it reengages with the back section.

\*\*\*Chair shown in Sure-Check Fusion III Spruce (XXX-043)



Figure 3.5-1



Figure 3.5-2\*\*\*



Figure 3.5-3



Figure 3.5-4



Figure 3.5-5

## 3.6 ADJUSTABLE FOOTREST

### WARNING: PERSONAL INJURY HAZARD:

**⚠ WARNING: The VIC has a warning label on the top of the base cover that states: When chair is in nontransport mode: Patient must remain fully upright; patient must never be reclined; patient must never be left unattended.**

### 3.6.1 Repositioning the Footrest

The footrest has three positions:

- retracted (Fig. 3.6-1),
- lower (Fig. 3.6-2), and
- upper (Fig. 3.6-4).

#### To place footrest in lower position:

With the pan in the retracted position, pull out on the handles on either side of pan (Fig. 3.6-1). The footrest will drop into the lower position (Fig. 3.6-2).

#### To place footrest in upper position:

Grasp the handles on both sides of the pan and tilt the pan up while lifting (Fig. 3.6-3). Once the pan is up all the way, tilt the pan out until it locks into upper position (Fig. 3.6-4).

#### To return the footrest to retracted position:

Tilt the pan up while letting it slide down, if needed, (Fig. 3.6-3), into the lower position (Fig. 3.6-2); continue tilting the footrest until it is in the retracted position (Fig. 3.6-1).

**\*\*\*Chair shown in Sure-Check Fusion III Spruce (XXX-043)**



Figure 3.6-1\*\*\*



Figure 3.6-2



Figure 3.6-3



Figure 3.6-4

## 3.7 HINGING RAILS

### 3.7.1 Repositioning the Rail

The chair rail has two positions, up and down. Both positions lock the rail into place.

#### To lower the rail:

Apply lateral force to the top of the rail (Fig. 3.7-1) and pull on the red rail handle (Fig. 3.7-2). Allow the rail to rotate all the way down until it locks into place in the rail catch (Fig. 3.7-4).

#### To raise the rail:

Grasp the rail and lift it until the latching mechanism locks into place. (Fig. 3.7-2).

**⚠ WARNING:** When patient is seated in the chair, ensure the side rails are up and the patient is secured with restraint straps.

**⚠ WARNING:** Rail release handle will not release unless force is applied laterally to outside top of rail.

**⚠ WARNING:** The chair has a warning label located on both side rails indicating a pinch point between seat section and side rail.



Figure 3.7-1\*\*\*



Figure 3.7-2  
(Latch shown in up position)



Figure 3.7-3  
(Rail shown when rotated down)



Figure 3.7-4  
(Latch shown when rotated down)

\*\*\*Chair shown in Sure-Check Fusion III Spruce (XXX-043)

### 3.8 VIC ROTATING INSTRUCTIONS (TRANSPORT AND NONTRANSPORT MODE)

#### WARNING: PERSONAL INJURY HAZARD:

- ⚠ **WARNING:** When the VIC is not in use, **DO NOT** leave it in a recline position.
- ⚠ **WARNING:** When transporting patient, the patient should be placed in a fully upright position with chair in low height.
- ⚠ **WARNING:** The patient should **NEVER** be transported when the VIC is in a recline position.

#### 3.8.1 Mode Definitions

##### Transport Mode

The VIC is in transport mode when the green arrow by the seat lock knob is aligned with the green arrow on the base, circled in red in Fig. 3.8-1, and the seat is locked, as shown in Figs. 3.8-1 and 3.8-2.

##### Nontransport Mode

The VIC is in nontransport mode is when the seat has been locked 90° counterclockwise from transport mode, as shown in Figs. 3.8-3 and 3.8-4.

- ⚠ **WARNING:** Nontransport mode is to be used **ONLY** for performing clinical procedures.



Figure 3.8-1  
(VIC in transport mode)

Figure 3.8-2



Figure 3.8-3\*\*\*  
(VIC in nontransport mode)

\*\*\*Chair shown in Sure-Check Fusion III Spruce (XXX-043)



Figure 3.8-4  
(VIC in nontransport mode)

## WARNING: PERSONAL INJURY HAZARD:

- ⚠ **WARNING:** The VIC is NOT intended to replace a gurney or stretcher.
- ⚠ **WARNING:** When the VIC is in nontransport mode, the patient must remain fully upright, patient should NEVER be reclined, and patient must never be unattended.
- ⚠ **WARNING:** When transporting patient, the patient should be placed in a fully upright position with chair in low height.
- ⚠ **WARNING:** The patient should NEVER be transported when the VIC is in a recline position.
- ⚠ **WARNING:** When patient is seated in the chair, the side rails should be up and the patient should be secured with safety straps.



Figure 3.8-5



Figure 3.8-6

### 3.8.2 Nontransport Mode (Anterior / Posterior Position)

#### To Enter Nontransport Mode

Lock the caster brakes: depress the red pedal at the foot end of the unit on the patient's left, circled in red in Fig. 3.8-5, to approximately 45°.

Secure patient with safety straps. Elevate chair to maximum height (Fig. 3.8-7). Pull out on the seat lock knob, circled in red in Fig. 3.8-6, to release lock. Rotate chair counterclockwise until it locks into nontransport mode (Fig. 3.8-7).



Figure 3.8-7\*\*\*  
(VIC in nontransport mode)

### 3.8.3 Transport Mode (Lateral Position)

#### To Enter Transport Mode

Pull out on the seat lock knob, circled in red in Fig. 3.8-6, to release lock. Rotate the chair clockwise 90° until it locks into transport mode (Fig. 3.8-8). Ensure the chair is locked in transport mode (Fig. 3.8-8) before transporting or reclining the patient. The green arrow label on the seat will be in line with the green arrow label on the base circled in red in Fig. 3.8-8.

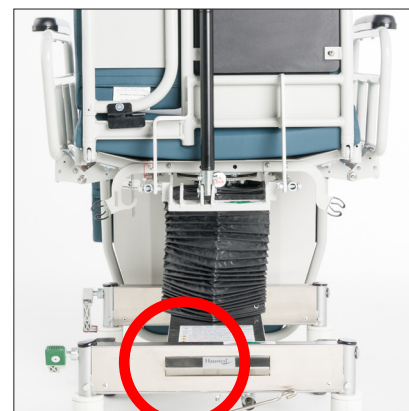

Figure 3.8-8

\*\*\*Chair shown in Sure-Check Fusion III Spruce (XXX-043)

### 3.9 PATIENT TRANSFER INSTRUCTIONS

#### WARNING: PERSONAL INJURY HAZARD:

- ⚠ **WARNING:** The VIC429ST Video Imaging Chair has a maximum patient weight capacity of 324 lb (147 kg), **EVENLY DISTRIBUTED.**
- ⚠ **WARNING:** The VIC is **NOT** intended to replace a stretcher or gurney.
- ⚠ **WARNING:** **DO NOT** sit on end - as tipping may occur.
- ⚠ **WARNING:** **DO NOT** stand on footrest - as tipping may occur.
- ⚠ **WARNING:** When the VIC is **NOT** in use, **DO NOT** leave it in a recline position.
- ⚠ **WARNING:** When patient is seated in the chair, ensure the side rails are up and the patient is secured with patient safety straps.
- ⚠ **WARNING:** Patient entry, egress and transfer from the chair should **ALWAYS** be from the center side rail location with the side rail in the down position and the brakes locked.
- ⚠ **WARNING:** At **NO TIME** should the patient be permitted to enter or exit from the ends of the VIC when in partial or total recline position.
- ⚠ **WARNING:** When transporting patient, the patient should be placed in a fully upright position with chair in low height. The patient should never be transported when the VIC is in a recline position.
- ⚠ **WARNING:** The brakes should **ALWAYS** be applied when patient is not being transported.
- ⚠ **WARNING:** When chair is in nontransport mode, patient must remain fully upright; patient must never be reclined; patient must never be left unattended.

## Definition of Terms Used in the Following Instructions (see Fig. 3.10-1 on next page).

### TRANSFER SIDE TERMS

**Secondary Patient Device:** The transfer side will always be located on the **attendant's** right side when standing at the patient's foot end facing the patient.

**VIC:** The transfer side will always be located on the **patient's** right side.

### Transfer of patient from VIC to a Secondary Device

#### Patient Preparation

Leave patient secured with restraint straps until actual patient transfer is to begin.

#### Secondary Device Preparation

1. Lock the secondary device caster brakes.
2. Place secondary device in lowest vertical position.
3. Level patient surface to a horizontal plane.
4. Lower patient rail on transfer side of secondary device.

#### VIC Preparation

1. Ensure VIC is in transport mode (see Section 3-8).
2. Adjust VIC height so the seat section is level with patient surface of secondary device.
3. Lower the patient side rail on VIC's transfer side.
4. Move the VIC so that both devices are facing each another on the specified transfer sides.
5. Recline the VIC to horizontal plane.
6. Maneuver VIC so that the transfer sides of the two devices are making contact (limit transfer gap as much as possible).
7. Lock the VIC caster brakes.

### 3.10 PERFORMING PATIENT TRANSFER

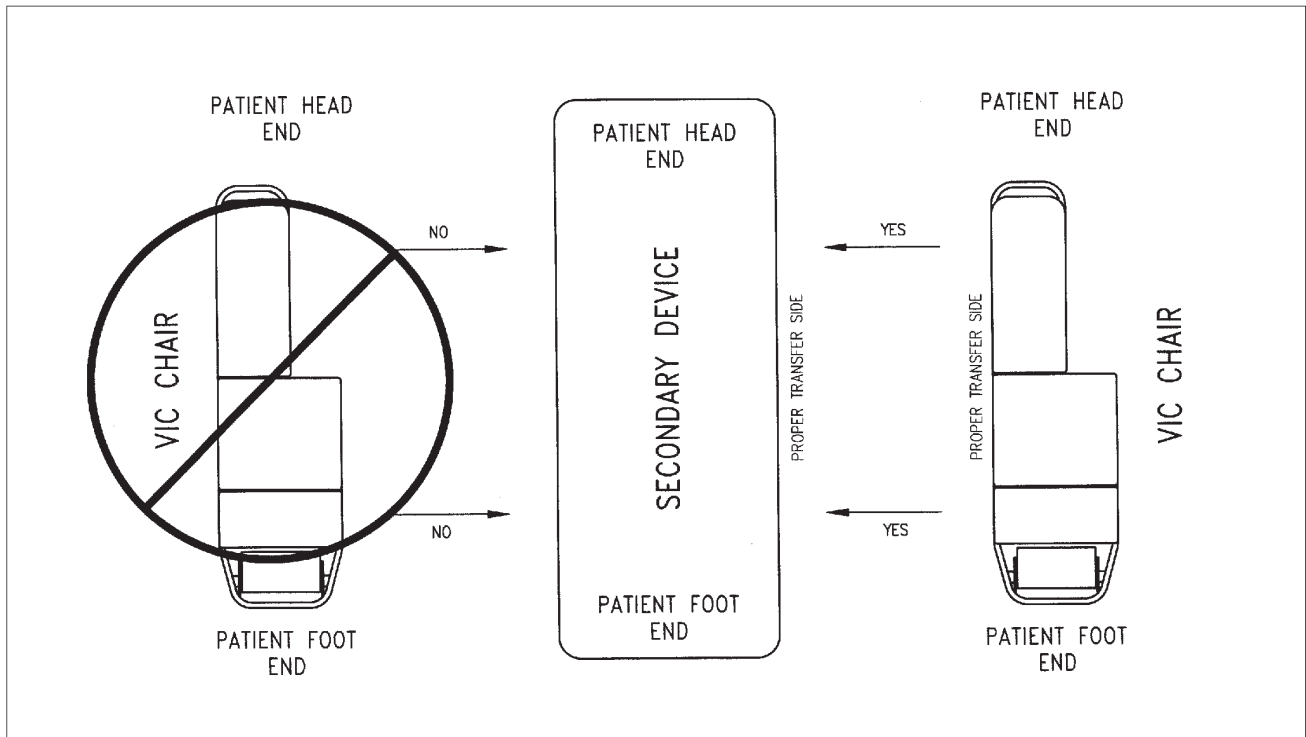

Figure 3.10-1

#### Patient Transfer

1. Release patient safety straps.
2. Transfer patient, following instructions on previous page.

#### Patient Transfer from a Secondary Device to VIC

Follow the same procedure as in "transferring from VIC to a secondary device" on previous page except: you must verify that the VIC is positioned so that the patient's abdomen is in line with the chair seat before attempting to transfer a patient to the VIC; otherwise tipping may occur.

## 4 PREVENTIVE MAINTENANCE FOR THE USER

Component	Cleaning Procedure	Schedule	Cleaning Agent *	Special Notes
Pads / Mattresses	Wipe with damp cloth to remove any foreign material	After each use	Routine hospital grade disinfectants, soap and water	Use only medium strength cleaners Do not steam clean or pressure wash
Chair	Wipe with damp cloth to remove any foreign material		Routine hospital grade disinfectants, soap and water	Lubricate pivot points after cleaning
Mechanical chair components	Wipe with damp cloth to remove any foreign material		Routine hospital grade disinfectants, soap and water	Lubricate pivot points after cleaning
Mechanical accessories	Wipe with damp cloth to remove any foreign material		Routine hospital grade disinfectants, soap and water	Lubricate pivot points after cleaning
Procedure	Schedule	Material		
Lubricate all actuator mounting pins	Every 6 months	Lithium-based grease		
<b>⚠ NEVER LUBRICATE COLUMN ⚠</b>				
Inspect all fasteners to ensure proper fit, position and tightness, including nuts, bolts, etc.	Every 3 months	Proper size wrench and screwdriver		
Inspect all surfaces and remove any sharp or burred areas; apply touch-up paint where required		Metal file, proper color paint (specify color when ordering)		
<b>* Disinfecting and Cleaning Upholstery - ALWAYS follow manufacturer's recommended dilution</b>				
Disinfectants for vinyl products	Phenolic disinfectants are the best choice for vinyl			
	Properly diluted quaternaries are also acceptable for vinyl			
	Quaternary / Isopropyl disinfectants ARE NOT recommended for vinyl			
Disinfectants for urethane products (Standard Upholstery)	Quaternary disinfectants are recommended for urethane			
	Quaternary / Isopropyl disinfectants are recommended for urethane			
	Phenolics SHOULD BE AVOIDED on urethane			
Disinfectants for all products	All fabrics may be cleaned with a 1:10 dilution of household bleaches containing 5.25% sodium hypochlorite as recommended by the Centers for Disease Control in Atlanta, Georgia; there is no harmful effect on the fabric			
	Disinfectants applied at full concentration or in highly concentrated solutions will decrease the useful life of fabric			
	Iodophor-type disinfectants used on fabric may result in staining			
Soils or Stains	Use neutral soapsuds and lukewarm water; DO NOT use harsh cleansers, solvents or detergents			
Hard-To-Clean Spots	Use standard household / vinyl cleansers and a soft bristle brush on troublesome spots or stains; presoak heavy, dried-on soil			
Laundering	Laundering Vinyl-laminated, Polyurethane-coated, or Rubber-coated fabric IS NOT recommended; laundering may substantially decrease the useful life of the fabric			

**▲ NOTICE – POSSIBLE EQUIPMENT DAMAGE HAZARD:** Steam cleaning and pressure washing of chair is not recommended and can void warranty.

*Info: For more detailed information, contact GF Health Products, Inc. at 1.770.368.4700.*

*Info: GF Health Products, Inc. offers customized Preventative Maintenance Service Programs for Hausted products; contact your GF sales representative for further information.*

## 5 OPTIONAL ACCESSORIES

**⚠ WARNING:** Use only accessories approved by GF Health Products, Inc. with this device. The use of accessories, transducers, and cables other than those specified by the manufacturer may result in increased emissions or decreased immunity of Hausted equipment.

*Info: To order accessories, or for more detailed information on accessories, please contact GF Health Products, Inc. at 1.770.368.4700.*

ITEM NO.	DESCRIPTION
HSA063600	PEDIATRIC POSITIONER (36"X7")
HSA063700	PEDIATRIC POSITIONER (48" X 10")
HSA063800	PEDIATRIC POSITIONER (60" X 13")
HSA0658	FOAM WEDGE, PATIENT POSITIONING
HSA071600	X-WIDE SAFETY STRAPS WITH HOOK AND LOOP
HSA071700	UNIVERSAL HEAD SAFETY STRAP
HSA0721	PUSHBAR (REMOVABLE, STAINLESS STEEL - COMES STANDARD)
HSA4002	VIC BACK EXTENSION ASSEMBLY VIC429ST ONLY (MFG AFTER 4/98)
H000018	TELESCOPING IV ROD, 27" TO 50", 2-SECTION WITH HOLDER (STAINLESS)
HAPC01200	SAFETY STRAPS WITH HOOK AND LOOP, COMES STANDARD WITH 2 STRAPS
HAPC02100	PATIENT TRAY
HAPC14D00	OXYGEN TANK HOLDER
H06599000	ARM BOARD WITH PAD (FOR SITTING)
HSA4002	VIC BACK EXTENSION FIELD UPGRADE VIC429ST ONLY (MFG AFTER 4/98)

## 6 GF HEALTH PRODUCTS, INC. LIMITED WARRANTY FOR HAUSTED BRAND

### SCOPE OF WARRANTY

GF Health Products, Inc. ("GF") warrants to the original purchaser only that it will replace or repair components, at GF's sole discretion, that are defective in material or workmanship under normal use and service. All warranties are conditioned upon the proper use of the products strictly in accordance with good commercial practice and applicable GF instructions and manuals, including proper use and maintenance. To the extent that a third party warrants a component, GF conveys all of its rights under that warranty to the original purchaser, to the extent permitted. This limited warranty shall only apply to defects that are reported in accordance with the provisions set forth in this warranty document, within the applicable warranty period and which, upon examination by GF or its authorized representative, prove to be a warranty item. (See Obtaining Warranty Service below) This limited warranty is not transferable.

The warranted components and time periods are set forth below:

COMPONENT.....	PARTS WARRANTY
Frame.....	5 years
Casters.....	1 year
Electrical components.....	2 years
Hydraulics.....	1 year
Mechanical Components.....	3 years
Original and Replacement Upholstered Tops †.....	1 year
Replacement Parts ‡.....	90 days

\* Labor is not included in the warranty.

† Upholstery is only warranted on material supplied by GF.

‡ The warranty period is as designated above. If a part is replaced under warranty, the original warranty period will not be affected. All other replacement parts will be subject to the warranty period specified.

The applicable warranty period shall commence from date of shipment to the original customer, unless there is an expiration date on the component in which case the warranty shall expire on the earlier of warranty period or the expiration date.

### OBTAINING WARRANTY SERVICE

Customers located in the United States who wish to report a warranty issue, must contact GF directly by calling 1.770.368.4700 or by e-mailing a request to [cs@grahamfield.com](mailto:cs@grahamfield.com). Customers located outside the United States must contact the Distributor from whom they purchased the products. In both cases, further directions will be provided once the initial contact is made. This limited warranty shall only apply to defects that are reported within the applicable warranty period. Failure to abide by the specific directions will result in denial of the warranty claim.

The warranty does not cover and GF shall not be liable for the following:

1. Defects, damage, or other conditions caused, in whole or in part, by misuse, abuse, negligence, alteration, accident, freight damage, tampering or failure to seek and obtain repair or replacement in a timely manner;
2. Products which are not installed, used, or properly cleaned and maintained as required in the official manual for the applicable product;
3. Products considered to be of a non-durable nature including, but not limited to: filters, fuses, gaskets, lubricants, and charts;
4. Accessories or parts not provided by GF;
5. Matching of color, grain or texture except to commercially acceptable standards;
6. Changes in color caused by natural or artificial light;
7. Charges by anyone for adjustments, repairs, replacement parts, installation or other work performed upon or in connection with such products which are not expressly authorized in writing, in advance, by GF;
8. Any labor or shipping charges incurred in the replacement part installation or repair;
9. Costs and expenses of regular maintenance and cleaning; and
10. Representations and warranties made by any person or entity other than GF.

### ENTIRE WARRANTY, EXCLUSIVE REMEDY AND CONSEQUENTIAL DAMAGES DISCLAIMER

THIS WARRANTY IS GF'S ONLY WARRANTY AND IS IN LIEU OF ALL OTHER WARRANTIES, EXPRESS OR IMPLIED. GF MAKES NO IMPLIED WARRANTIES OF ANY KIND INCLUDING ANY IMPLIED WARRANTIES OF MERCHANTABILITY OR FITNESS FOR A PARTICULAR PURPOSE. IF ANY MODEL OR SAMPLE WAS SHOWN TO THE CUSTOMER, SUCH MODEL OR SAMPLE WAS USED MERELY TO ILLUSTRATE THE GENERAL TYPE AND QUALITY OF THE PRODUCT AND NOT TO REPRESENT THAT THE PRODUCT WOULD NECESSARILY CONFORM TO THE MODEL OR SAMPLE IN ALL RESPECTS. THIS WARRANTY IS LIMITED TO THE REPAIR OR REPLACEMENT OF THE DEFECTIVE PARTS. GF SHALL NOT BE LIABLE FOR AND HEREBY DISCLAIMS ANY DIRECT, SPECIAL, INDIRECT, INCIDENTAL, EXEMPLARY OR CONSEQUENTIAL DAMAGES, INCLUDING, BUT NOT LIMITED TO: DAMAGES FOR LOSS OF PROFITS OR INCOME, LOSS OF USE, DOWNTIME, COVER, OR EMPLOYEE OR INDEPENDENT CONTRACTOR WAGES, PAYMENTS AND BENEFITS. CERTAIN STATES MAY CONFER ADDITIONAL RIGHTS REGARDING WARRANTIES AND IN THOSE STATES GF'S LIABILITY AND THE LIABILITY OF GF'S SUPPLIERS, SHALL BE LIMITED TO THE FULLEST EXTENT PERMITTED BY LAW.

The warranties contained herein, together with GF's current Terms and Conditions, contain all the representations and warranties with respect to the subject matter of this document, and supersede all prior negotiations, agreements and understandings with respect thereto. The recipient of this document hereby acknowledges and represents that it has not relied on any representation, assertion, guarantee, warranty, collateral contract or other assurance, except those set out in this document.

For additional information on this product or this warranty, please contact a GF Customer Service Representative.

### NOTES:

- 1) Additional terms and conditions may apply. See GF's General Terms and Conditions on its website: [www.grahamfield.com](http://www.grahamfield.com).
- 2) Freight claims must be notated on the appropriate shipping documents and must be made with immediacy. International, federal and state regulations govern specific requirements for freight claims. Failure to abide by those regulations may result in a denial of the freight claim. GF will assist you in filing the freight claim.
- 3) Claims for any short shipment must be made within three (3) days of the invoice date.

## 7 DISPOSAL AND KEY TO SYMBOLS

### DISPOSAL

Hausted equipment and accessories can be disposed of.

















We recommend disassembling and dividing the equipment and components into different waste groups such as: metal, cable, electronic, recoverable resource and plastic for recycling or combustion.

Most plastic components are provided with a plastic types code and fiber content to aid sorting of plastic parts.

Product	Metal Scrap	Cable Scrap	Electronic Scrap	Plastic Recycling or Combustion
VIC429ST	X	X	None	X

### KEY TO SYMBOLS

The following symbols are used on Hausted product labels.

	Protective Earth		Manufacturer
	Earth Ground		Keep Dry
	General Warning Sign		Fragile, Handle with Care
	CE Mark		Electrical and Electronic Equipment
	ETL		Consult Instructions for Use
	European Authorized Representative		Caution
	Disconnect before Service		Pinch Point
	Medical Device		Unique Device Identifier

www.hausted.com  
www.grahamfield.com

## 8 INDEX

### A

Accessories, optional, list 23  
Adjustable footrest 16  
Advisory 4  
A word from GF Health Products, Inc. 4

### B

Back, reclining 14  
Back, returning to upright position 14  
Back, Trendelenburg position 14  
Brakes, applying 12  
Brakes, releasing 12  
Braking and steering operation 12

### C

CAUTION statement, significance 5  
Cleaning 22

### D

DANGER statement, significance 5  
DANGER / WARNING / CAUTION / NOTICE Summary 5  
Degree indicator, back 14  
Disposal 26

### E

Environmental conditions 7

### H

Height and patient surface adjustment 16

### I

Independent leg section 15  
Indications for use 4  
Info statement, significance 5  
Introduction 4

### L

Leg, independent operation 15  
Leg, returning to chair mode 15  
Limited warranty 24

### N

Nontransport mode 18  
Nontransport mode, enter 19  
NOTICE statement, significance 5

### O

Operating instructions 8

### P

Patient transfer instructions 20  
Patient transfer, performing 21  
Preventive maintenance for the user 22

### R

Rail, lower 17  
Rail, raise 17  
Rail, repositioning 17  
Rails, hinging 17

### S

Safety statements, significance of 5  
Service information 4  
Steering lock, applying 12  
Steering lock, releasing 12  
Symbols key, Hausted product labels 26

### T

Top adjustment 13  
Top, lowering 13  
Top, raising 13  
Transport mode 18  
Transport mode, enter 19  
Trendelenburg position 14

### U

Uncrating instructions 7  
Unpacking instructions 7

### V

VIC429ST features, illustrated 10  
VIC429ST specifications 11  
VIC429ST standard features 8  
VIC rotating instructions (transport and nontransport mode) 18

### W

Warnings 5  
WARNINGS and CAUTIONS, list 5  
WARNING statements 5  
WARNING statement, significance 5  
Warranty, limited 24

**Hausted**<sup>®</sup>  
by graham-field



---

Manufactured By:  
GF Health Products, Inc.  
1 Graham-Field Way, Atlanta, GA 30340  
Made in USA

© 2021, GF Health Products, Inc. All Rights Reserved.  
Hausted is a registered trademark of GF Health Products, Inc.

HP\_VIC429-INS-LAB-RevC25



+1 770.368.4700

Information contained herein is subject to change without notice.  
The most current and complete product information can be found on our website.  
[www.hausted.com](http://www.hausted.com) | [www.grahamfield.com](http://www.grahamfield.com)

