



4100 SERIES TREATMENT TABLE INSTALLATION AND OPERATION MANUAL

SAVE THIS MANUAL FOR FUTURE USE.

CONTENTS

1 INTRODUCTION	3
INTENDED USE.....	3
EQUIPMENT SYMBOL KEY	4
2 SAFETY PRECAUTIONS	4
WARNINGS.....	5
3 FEATURES	6
TREATMENT TABLE COMPONENT IDENTIFICATION.....	6
TREATMENT TABLE MODEL NUMBER OPTIONS.....	6
4 UNPACKING	7
UNPACKING THE TREATMENT TABLE.....	7
TREATMENT TABLE COMPONENTS	7
5 ASSEMBLY.....	8
6 INSTALLATION	10
LEVELING THE TREATMENT TABLE.....	10
7 OPERATION.....	11
TREATMENT TABLE BACK ANGLE RANGE.....	11
8 MAINTENANCE	12
CLEANING.....	12
MAINTENANCE.....	13
DISPOSAL.....	14
9 TEST PARAMETERS	15
10 SPECIFICATIONS	16
11 LIMITED WARRANTY.....	17
12 INDEX.....	19



1 INTRODUCTION

Congratulations on your purchase of the Hausted 4100 Series Treatment Table. The following pages will provide you with important safety and operating instructions on the installation and operation of the Treatment Table, as well as maintenance and warranty information. Read this manual carefully before operating your Treatment Table and refer to it as often as needed. Consult your authorized distributor and / or healthcare professional with any questions or concerns regarding safe and effective techniques for operating your Treatment Table.

This guide covers the use of the Hausted 4100, 4103, and 4105 Series Treatment Tables. Keep in mind that the basic safety procedures included in this manual are to be used as a guide only. You may find it necessary to develop your own unique methods for safely utilizing the Treatment Table. Again, consult your healthcare professionals for their recommendations and never hesitate to ask for their assistance.



Upon receipt of the Treatment Table, inspect it closely to ensure that nothing is damaged, there are no loose or broken parts, that all Treatment Table parts are in the proper place, etc. Immediately replace any worn or broken components. Your Treatment Table should receive maintenance on a regular schedule and should be inspected frequently for proper operation. Contact GF Tech Support at 1.770.368.4700 with any maintenance concerns.

Info: Before attempting to install the Treatment Table, refer to the section titled “INSTALLATION” contained elsewhere in this manual. Contact GF Tech Support at 1.770.368.4700 or your GF authorized distributor if additional assistance is needed.

INTENDED USE

The Hausted 4105, 4103, and 4100 Series Treatment Tables are intended to support patients during medical treatment. During these treatments, medical professionals use adjusting mechanisms to manipulate and position the table to provide patient support and closer treatment of a portion of or the entire patient.

EQUIPMENT SYMBOL KEY

Symbol	Meaning
	Refer to Manual
	Shipping Orientation
	Maximum Weight Capacity 500 lb (317 Kg) Evenly Distributed

2 SAFETY PRECAUTIONS

IMPORTANT: Before installing or using Treatment Table, read and then follow the following safety precautions and warnings. Failure to do so could result in serious personal injury or damage to your Treatment Table.

Always consult your healthcare professional to determine safe methods most suitable for your individual abilities. Protect yourself, your attendant and Treatment Table by having it serviced regularly. If you experience any malfunction, contact GF Tech Support at 1.770.368.4700 or your GF authorized distributor immediately, as a hazardous condition could result, causing personal injury or damage to your Treatment Table.

Periodic inspection, adjustment and replacement of worn parts are necessary to provide years of excellent service. Refer to *CARE AND MAINTENANCE* section of this manual.

Maintenance **MUST** be performed by qualified personnel **ONLY**.

Significance of safety statements

Note the following special statements, used throughout this manual, and their significance:

- ⚠ DANGER:** Indicates a potential hazard situation or unsafe practice that, if not avoided, will result in death or serious personal injury.
- ⚠ WARNING:** Indicates a potential hazard situation or unsafe practice that, if not avoided, could result in death or serious personal injury.
- ⚠ CAUTION:** Indicates a potential hazard situation or unsafe practice that, if not avoided, could result in minor or moderate personal injury.
- ▲ NOTICE:** Indicates a potential hazard situation or unsafe practice that, if not avoided, could result in product or property damage.

Info: Provides application recommendations or other useful information to ensure that you get the most from your product.

WARNINGS

- ⚠ WARNING: Important! Read and understand these instructions before assembling or using the Hausted 4105, 4103, and 4100 Series Treatment Tables. If you do not understand any part of these warnings, cautions or instructions, contact a healthcare professional for direction in the use of this product. If the Treatment Table is not properly assembled, personal injury and damage to the treatment table could result.**
- ⚠ WARNING: If components are damaged or missing, contact your GF authorized distributor immediately. DO NOT use substitute parts. Use only GF replacement parts. The use of non-GF replacement parts could cause personal injury, property damage, and void the warranty.**
- ⚠ WARNING: Unauthorized modification of your Treatment Table could cause personal injury, property damage, and void the warranty.**
- ⚠ WARNING: The Hausted 4105, 4103, and 4100 Series Treatment Table's maximum weight capacity are 500 lb (317 kg), EVENLY DISTRIBUTED. DO NOT exceed the maximum weight capacity.**
- ⚠ WARNING: GF Health Products, Inc. assumes no responsibility for any personal injury or property damage caused by improper assembly or use of this product.**
- ⚠ WARNING: Check all parts for shipping damage before using. In case of damage, DO NOT USE the equipment. Contact the carrier or your GF authorized distributor for further instructions.**
- ⚠ WARNING: Unauthorized modification of the Treatment Table or the use of non-GF replacement parts may change the structure of the table and could create a hazardous condition, which may result in serious injury and void the warranty.**
- ⚠ WARNING: GF Health Products, Inc. ("GF") specifically disclaims responsibility for any personal injury or property damage which may occur during any use which does not comply with federal, state or local laws or ordinances.**

3 FEATURES

TREATMENT TABLE COMPONENT IDENTIFICATION



4 UNPACKING

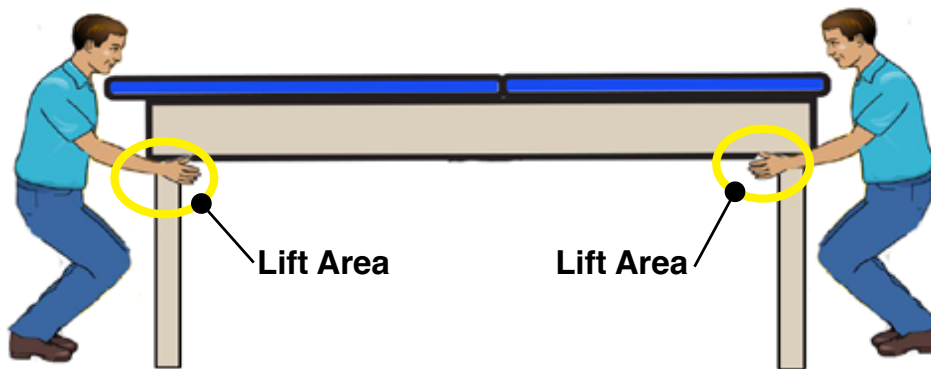

UNPACKING THE TREATMENT TABLE

⚠ WARNING: This exam table, as shipped, can weigh as much as 218 lb (99 kg) – use sufficient personnel to lift and remove the exam table from the shipping pallet for placement into final location. **DO NOT** attempt to remove the exam table from the shipping pallet or move it without assistance. Use proper lifting technique, and see illustration above for proper lifting area; neglect of these procedures could result in serious injury.

▲ NOTICE: **DO NOT** Use a knife or other sharp object to open packaging – damage could occur to the treatment table upholstery or surface.

The treatment table is packaged in one corrugated cardboard carton.

1. Check for any obvious damage to the carton or its contents. If damage is evident, notify the carrier or your GF authorized distributor.
2. Carefully remove the boxed H-legs from the box (mounting hardware is in H-leg box).
3. Carefully remove shelf and drawer(s) if ordered.
4. Carefully remove upholstered top with frame, taking care not to damage upholstery.

INSPECTION

1. Examine the Examination Table for nicks, dents, scratches or other damage. If damage is evident, immediately notify the carrier or GF.
2. Inspect all components.
3. If damage to any component is evident, immediately notify the carrier or GF.

TREATMENT TABLE COMPONENTS

The corrugated cardboard carton contains:

Item	Quantity	Description
1	1	Upholstered top mounted to frame
2	2	H-leg boxed with eight L-brackets and mounting hardware (sixteen 1/4-20 x .75 in. Phillips Pan Head Screws to mount brackets)
3	8	Socket head cap screw 1/4-20 x 1.25 in. to mount H-leg corners
4	1	Shelf (series 4105, and 4103 only) with mounting hardware (four 1/4-20 x 1 in. Phillips Head Screws)
5	1 or 2	Drawer with mounting hardware (four 1/4-20 x 1 in. Phillips Head Screws per drawer)

5 ASSEMBLY

Tools required: #2 Phillips Screwdriver (preferably electric), 3/16 in. hex key

▲ **NOTICE:** Tabletop will be upside down during assembly. To prevent damage to upholstery, ensure you have a protective surface to place it on.

1. While being careful to prevent damage to upholstery, position the tabletop with upholstery down and metal frame up for access to underside.

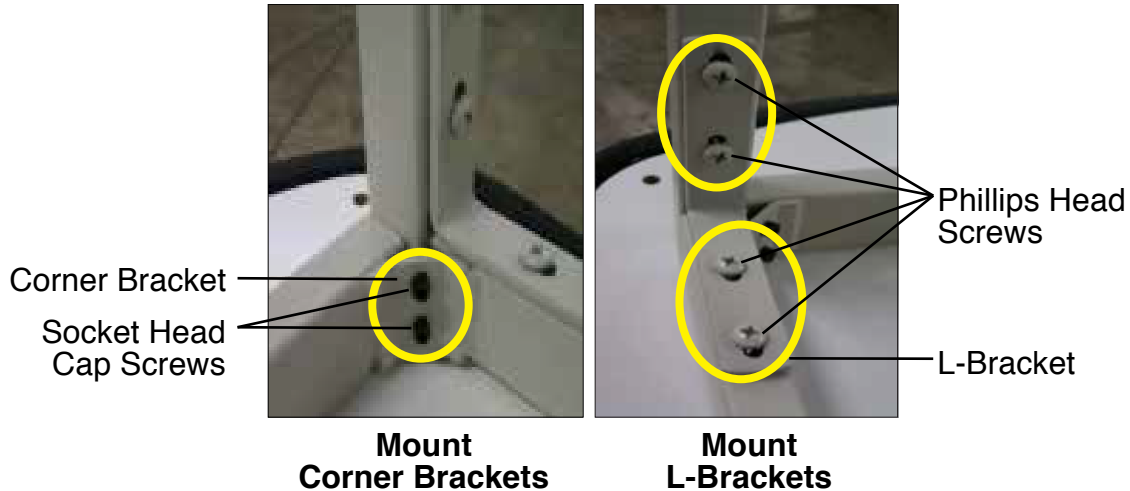

2. Position H-Legs in metal frame corners as shown above.
3. Mount the two socket head cap screws through the corner bracket into the leg as shown at left above. Use 3/16 in. hex key to tighten. Repeat for other three legs. Tighten securely.
4. Mount corner brackets using the eight L-Brackets and thirty-two Phillips head screws provided. Mount two L-Brackets per leg with Phillips head screws provided as shown at right above. Repeat for other three legs. Tighten securely with Phillips head screwdriver.

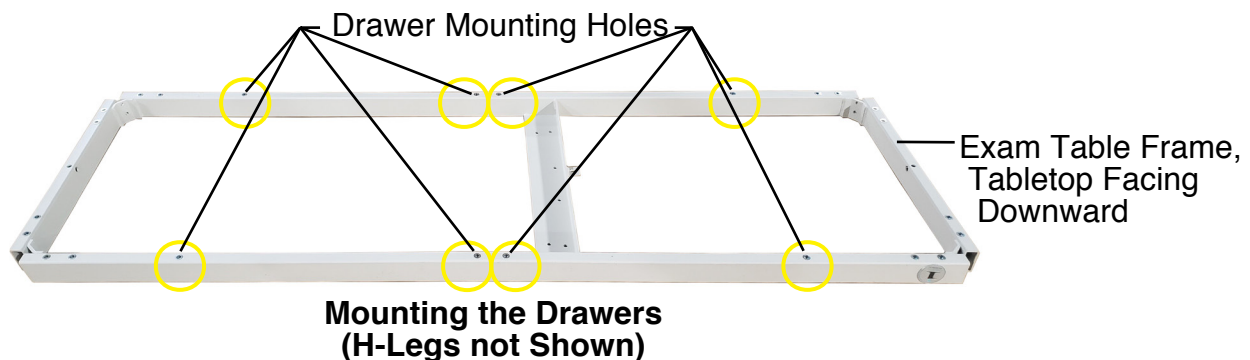

5. Mount drawer(s). Drawers mount to bottom side of treatment table frame through mounting holes, on bottom of tabletop, shown above. Mount drawer(s) using the enclosed four 1/4-20 x 1 in. Phillips Head Screws per drawer. Tighten securely with Phillips head screwdriver.

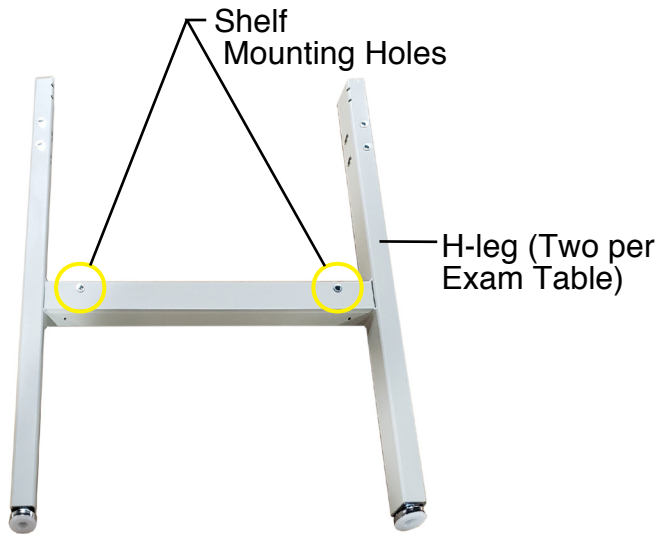

Mounting the Shelf (Tabletop and Drawer(s) not Shown)

6. Mount shelf (series 4105, and 4103 only). Mount the shelf to the inside of each H-Leg through mounting holes, shown above, with the shelf top facing the same direction as the tabletop, using the enclosed four 1/4-20 x 1 in. Phillips Head Screws. Tighten securely with Phillips head screwdriver.
7. Assembly is complete. While being careful to prevent damage to upholstery, use at least two people to lift the treatment table by the frame and position it in upright position.

⚠ WARNING: Do not use the treatment table unless it is assembled as described here. All eight L-Brackets and all four corner brackets MUST BE securely mounted as described above, or severe personal injury could result.

6 INSTALLATION

⚠ Level the treatment table as described below before use.

LEVELING THE TREATMENT TABLE

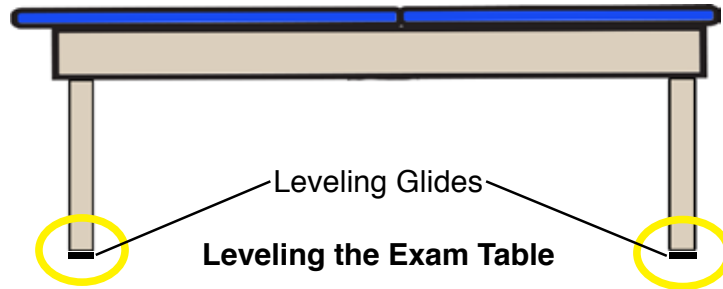

1. Locate Leveling Glides on Bottom of treatment table base, shown above (four total).
2. **To raise:** Turn Leveling Glide counterclockwise.
3. **To lower:** Turn Leveling Glide clockwise to lower.

⚠ **WARNING: Do not use the treatment table unless it is assembled as described here. All eight L-Brackets and all four corner brackets MUST BE securely mounted as described above, or severe personal injury could result.**

7 OPERATION

TREATMENT TABLE BACK ANGLE RANGE

⚠ WARNING: This treatment table is manually operated. Once the back reaches its maximum angle or a horizontal position, the back will stop moving. When the back is lowered, ensure hands or other objects are clear from the downward motion area.

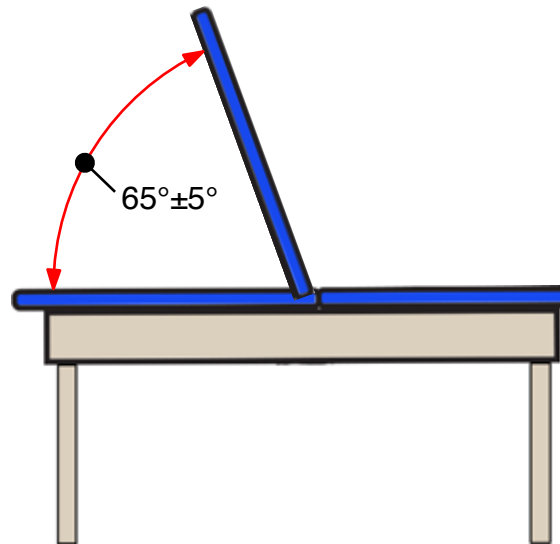

Back Angle Range

The treatment table features a limited back angle of $65^{\circ} \pm 5^{\circ}$ to accommodate heavier occupants comfortably, as shown above. Depending on table style, adjustable back may not be available. Please check table options on page 6 to determine style of treatment table.

Back Angle Adjustment

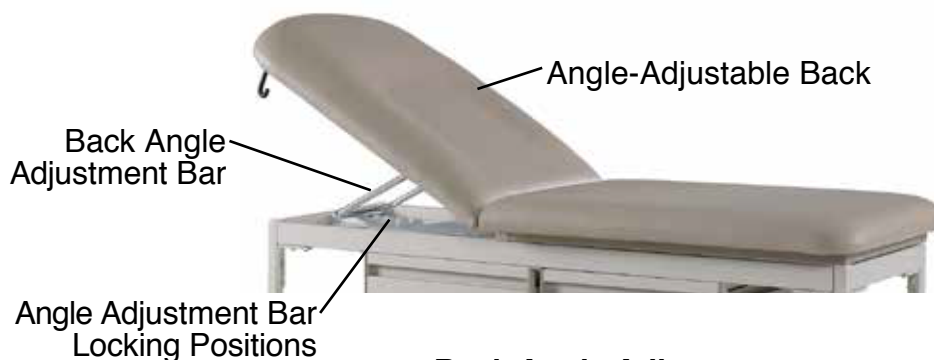

Back Angle Adjustment

To rotate the back, lift the edge of the upholstered top, rotate it to the desired position, and drop the adjustment bar into the desired locking position. The back is adjustable to 6 positions plus horizontal.

⚠ WARNING: Ensure the adjustment bar is locked in position before using treatment table.

8 MAINTENANCE

▲ **NOTICE – POSSIBLE EQUIPMENT DAMAGE HAZARD:** Steam cleaning and pressure washing of treatment table is not recommended and may void warranty.

⚠ **WARNING:** Service and repair of the Treatment Table **MUST** be performed by qualified personnel **ONLY**.

⚠ **WARNING:** Unauthorized modification of the Treatment Table or the use of non-GF replacement parts may change the structure of the table and could create a hazardous condition, which may result in serious injury and void the warranty.

Info: For more detailed information, please contact GF Health Products, Inc. at 1.770.368.4700.

CLEANING

▲ **NOTICE:** DO NOT wash Treatment Table under water pressure or steam clean.

▲ **NOTICE:** Cleaning solvents, dyes or sharp objects can damage upholstery. Promptly remove any excess fluids and rinse surface with clean water and wipe surface dry. Clean your upholstered top weekly. For basic cleaning use mild soap and water, rinse thoroughly and wipe surface dry.

Perform the following cleaning procedures as scheduled:

Component	Cleaning Procedure	Schedule	Cleaning Agent *	Special Notes
Pads	Wipe with damp cloth to remove any foreign material	After each use	Routine hospital grade disinfectants, soap and water	Use only medium strength cleaners Do not steam clean or pressure wash
Treatment table	Wipe with damp cloth to remove any foreign material	After each use	Routine hospital grade disinfectants, soap and water	Lubricate pivot points after cleaning

* Disinfecting and Cleaning Upholstery - ALWAYS follow manufacturer's recommended dilution	
Disinfectants for vinyl products	Phenolic disinfectants are the best choice for vinyl
	Properly diluted quaternaries are also acceptable for vinyl
	Quaternary / Isopropyl disinfectants ARE NOT recommended for vinyl
Disinfectants for urethane products	Quaternary disinfectants are recommended for urethane
	Quaternary / Isopropyl disinfectants are recommended for urethane
	Phenolics SHOULD BE AVOIDED on urethane
Disinfectants for all products	All fabrics may be cleaned with a 1:10 dilution of household bleaches containing 5.25% sodium hypochlorite as recommended by the Centers for Disease Control in Atlanta, Georgia; there is no harmful effect on the fabric
	Disinfectants applied at full concentration or in highly concentrated solutions will decrease the useful life of fabric
	Iodophor-type disinfectants used on fabric may result in staining
Soils or Stains	Use neutral soap suds and lukewarm water; DO NOT use harsh cleansers, solvents or detergents
Hard-To-Clean Spots	Use standard household / vinyl cleansers and a soft bristle brush on troublesome spots or stains; presoak heavy, dried-on soil
Laundering	Laundering Vinyl-laminated, Polyurethane-coated, or Rubber-coated fabric IS NOT recommended; laundering may substantially decrease the useful life of the fabric

MAINTENANCE

Have a qualified service technician perform the following maintenance as scheduled:

Maintenance Procedure	Materials / Action Required	Schedule
Inspect all mechanical functions for good operation	If replacement is needed, contact GF Health Products, Inc. at 1.770.368.4700	Every 3 months
Inspect all fasteners to ensure proper fit, position and tightness (including nuts, bolts, etc.)	Proper size wrench and screwdriver	
Lubricate all moving and sliding parts and hinge points	Lubricating oil, light-duty grease, wax stick lubricant or Never-Seez lubricant	
Inspect all surfaces and remove any sharp or burred areas; apply touch-up paint where required	Metal file, proper color paint (specify color when ordering)	

⚠ WARNING: After performing maintenance, if you believe a component or part is not functioning properly, immediately contact GF Tech Support at 1.770.368.4700, as a potentially hazardous condition could exist.

STORAGE

Store the repackaged Treatment Table in a dry area.

DISPOSAL

⚠ WARNING: During normal use of this product, it could become contaminated and may present a biohazard to waste sites.

This product may contain substances that could be harmful to the environment if disposed of in places (landfills) that are not appropriate according to local legislation.

At the end of this product's useful life, dispose of it in accordance with local requirements, or contact the manufacturer for advice. Recycle this product through your recycling facility or dispose of it in accordance with local regulations.

We recommend disassembling and dividing the equipment and components into different waste groups such as: metal, recoverable resource and plastic for recycling or combustion. Most plastic components are provided with a plastic types code and fiber content to aid sorting of plastic parts.

9 TEST PARAMETERS

California Technical Bulletin CA TB117-2013 Flammability Test

ANSI / BIFMA X5.4-2013 Sections 11, 12, 14, and 18
--

10 SPECIFICATIONS

Load Rating, All Models (Evenly Distributed)		500 lb (227 kg)
Model 4105 4105D 4103DD 4100	Shipping Weight	
	LB	KG
	190	86.2
	200	90.72
	210	86.2
4100	170	77.11
6-Position Adjustable Back Angle Range	Models 4103, 4100	0° (flat)
	Models 4105	0° to ~ 65°±5°
Table Frame Dimensions (W x L x H)		28 in. x 76 in. x 32 in. (71 cm x 193 cm x 81 cm)
Upholstered Top Dimensions (W x L)		29 in. x 76 in. (74 cm x 193 cm)
COM (Customer's Own Material) Requirements		4 yd. (3.66 m)
Pass Through Drawer Size (Drawer outside W x L x D)		18 in. x 20.5 in. x 4 in. (46 cm x 52 cm x 10 cm)
Paper Roll Sizes (W x Roll Diameter)		18 in. x 3 in. (46 cm x 8 cm)
		19 in. x 3 in. (48 cm x 8 cm)
		21 in. x 3 in. (53 cm x 8 cm)
Transport and Storage Conditions	Temperature Range	-20°F to 150°F (-29°C to 66°C)
	Relative Humidity	10% to 90%
Operating Conditions	Temperature Range	65°F to 85°F (18°C to 29°C)
	Relative Humidity	10% to 90%

11 LIMITED WARRANTY

SCOPE OF WARRANTY

GF Health Products, Inc. ("GF") warrants to the original purchaser only that it will replace or repair components, at GF's sole discretion, that are defective in material or workmanship under normal use and service. All warranties are conditioned upon the proper use of the products strictly in accordance with good commercial practice and applicable GF instructions and manuals, including proper use and maintenance. To the extent that a third party warrants a component, GF conveys all of its rights under that warranty to the original purchaser, to the extent permitted.

This limited warranty shall only apply to defects that are reported in accordance with the provisions set forth in this warranty document, within the applicable warranty period and which, upon treatmentation by GF or its authorized representative, prove to be a warranty item. (See Obtaining Warranty Service below) This limited warranty is not transferable.

Within the guidelines set forth in this document, the warranted components and time periods are set forth below:

Treatment Table Components *

- Base:..... 5 years
- Mechanical Components:..... 3 years
- Original and Replacement Upholstered Tops †: 1 year
- Replacement Parts ‡:..... 90 days

* Labor is not included in the warranty.

† Upholstery is only warranted on material supplied by GF.

‡ The warranty period is as designated above. If a part is replaced under warranty, the original warranty period will not be affected. All other replacement parts will be subject to the warranty period specified.

The applicable warranty period shall commence from date of shipment to the original customer, unless there is an expiration date on the component in which case the warranty shall expire on the earlier of warranty period or the expiration date.

OBTAINING WARRANTY SERVICE

This limited warranty shall only apply to defects that are reported to the Distributor from whom the Customer purchased the product within the applicable warranty period. If there is not a Distributor, you must contact GF directly by calling 1.770.368.4700, or by e-mailing a request to GF@grahamfield.com. Specific directions will be provided by the Customer Service Representative. Failure to abide by the specific directions will result in denial of the warranty claim.

The warranty does not cover and GF shall not be liable for the following:

- 1) Defects, damage, or other conditions caused, in whole or in part, by misuse, abuse, negligence, alteration, accident, freight damage, tampering or failure to seek and obtain repair or replacement in a timely manner;
- 2) Products which are not installed, used, or properly cleaned and maintained as required in the official manual for the applicable product;
- 3) Products considered to be of a non-durable nature including, but not limited to: filters, fuses, gaskets, lubricants, and charts;
- 4) Accessories or parts not provided by GF;
- 5) Matching of color, grain or texture except to commercially acceptable standards;
- 6) Changes in color caused by natural or artificial light;
- 7) Charges by anyone for adjustments, repairs, replacement parts, installation or other work performed upon or in connection with such products which are not expressly authorized in writing, in advance, by GF;
- 8) Any labor or shipping charges incurred in the replacement part installation or repair;
- 9) Costs and expenses of regular maintenance and cleaning; and
- 10) Representations and warranties made by any person or entity other than GF.

ENTIRE WARRANTY, EXCLUSIVE REMEDY AND CONSEQUENTIAL DAMAGES DISCLAIMER

THIS WARRANTY IS GF'S ONLY WARRANTY AND IS IN LIEU OF ALL OTHER WARRANTIES, EXPRESS OR IMPLIED. GF MAKES NO IMPLIED WARRANTIES OF ANY KIND INCLUDING ANY IMPLIED WARRANTIES OF MERCHANTABILITY OR FITNESS FOR A PARTICULAR PURPOSE. IF ANY MODEL OR SAMPLE WAS SHOWN TO THE CUSTOMER, SUCH MODEL OR SAMPLE WAS USED MERELY TO ILLUSTRATE THE GENERAL TYPE AND QUALITY OF THE PRODUCT AND NOT TO REPRESENT THAT THE PRODUCT WOULD NECESSARILY CONFORM TO THE MODEL OR SAMPLE IN ALL RESPECTS. THIS WARRANTY IS LIMITED TO THE REPAIR OR REPLACEMENT OF THE DEFECTIVE PARTS. GF SHALL NOT BE LIABLE FOR AND HEREBY DISCLAIMS ANY DIRECT, SPECIAL, INDIRECT, INCIDENTAL, EXEMPLARY OR CONSEQUENTIAL DAMAGES, INCLUDING, BUT NOT LIMITED TO: DAMAGES FOR LOSS OF PROFITS OR INCOME, LOSS OF USE, DOWNTIME, COVER, OR EMPLOYEE OR INDEPENDENT CONTRACTOR WAGES, PAYMENTS AND BENEFITS. CERTAIN STATES MAY CONFER ADDITIONAL RIGHTS REGARDING WARRANTIES AND IN THOSE STATES GF'S LIABILITY AND THE LIABILITY OF GF'S SUPPLIERS, SHALL BE LIMITED TO THE FULLEST EXTENT PERMITTED BY LAW.

The warranties contained herein, together with GF's current Terms and Conditions, contain all the representations and warranties with respect to the subject matter of this document, and supersede all prior negotiations, agreements and understandings with respect thereto. The recipient of this document hereby acknowledges and represents that it has not relied on any representation, assertion, guarantee, warranty, collateral contract or other assurance, except those set out in this document.

For additional information on this product or this warranty, please contact an GF Customer Service Representative.

NOTES:

- 1) Additional terms and conditions may apply. See GF's General Terms and Conditions on its website and the specific warranties, which may accompany the specific product.
- 2) Freight claims must be notated on the appropriate shipping documents and must be made with immediacy. International, federal and state regulations govern specific requirements for freight claims. Failure to abide by those regulations may result in a denial of the freight claim. GF will assist you in filing the freight claim.
- 3) Claims for any short shipment must be made within three (3) days of the invoice date.

12 INDEX

A

Assembly 8

B

Back angle adjustment 10

Back angle range 10

C

CAUTION statement, significance 4

Cleaning 11

Components, treatment table 7

D

DANGER statement, significance 4

Disinfecting and cleaning upholstery 11

Disposal 12

E

Treatment table components 6

F

Features 6

I

Info statement, significance 4

Installation 9

Intended use 3

Introduction 3

L

Leveling glides 9

Leveling the treatment table 9

Lubrication 12

M

Maintenance 12

Model number options 6

Mount treatment table drawer(s) 8

Mount treatment table shelf 9

N

NOTICE statement, significance 4

O

Operation 10

S

Safety precautions 4

Safety statements, significance of 4

Specifications 16

Storage 14

Symbol key, equipment 3

T

Test Parameters 15

U

Unpacking 7

W

Warnings 4

WARNING statement, significance 3

Warranty, limited 17

Weight capacity, maximum 4

Hausted[®]
by graham-field

gf Proudly designed, engineered,
and assembled in the USA
of domestic and globally
sourced components.

Manufactured By:
GF Health Products, Inc.
1 Graham-Field Way, Atlanta, GA 30340
Made in USA

© 2019, GF Health Products, Inc. All Rights Reserved.
Hausted is a registered trademark of GF Health Products, Inc.

HA_4100-INS-LAB-RevC24



+1 770.368.4700

Information contained herein is subject to change without notice.
The most current and complete product information can be found on our website.
www.hausted.com | www.grahamfield.com

graham
field[™]